

Q. C. ENG. MFG. ENG. PROD. CONT. PRESS POLISHING TOOL ROOM MILLING ASSEMBLY CUSTOMER

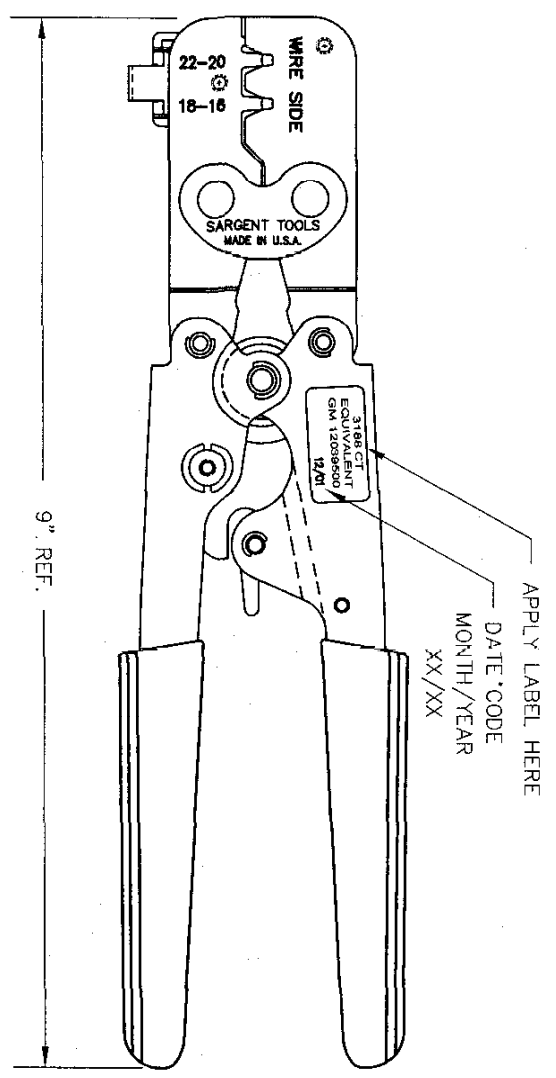

NEST	CONDUCTOR		INSULATION	
	H	W	H	W
22-20	.0425	.069	.0865	.098
	.0395	REF.	REF.	REF.
18-16	.0455	.089	.0865	.098
	.0425	REF.	REF.	REF.

GAGING USING WIRE SOLDER

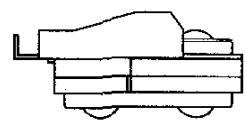
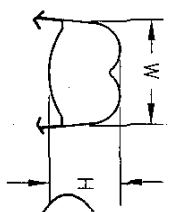

3188 CT

HEAT TREATED COMPONENTS
 BLACK OXIDE FINISH JAW ASSEMBLY
 BLACK OXIDE FINISH HANDLES
 RATCHET CONTROLLED RELEASE
 RATCHET RELEASE LEVER
 RATCHET SET TO RELEASE WHEN A 60-70 LB.
 LOAD IS APPLIED TO HANDLES APPROX. 1 3/4"
 FROM END OF HANDLES.
 YELLOW CUSHIONED PLASTIC GRIPS.
 WHITE FILL ALL STAMPINGS.

REVISION		EXP. RELEASE	TOLERANCES	
APPD.		FINAL RELEASE	FRAC. ±	
		12/7/01	2 DEC. ±	
		SUPERSIZES	3 DEC. ±	
		SCALE	4 DEC. ±	
		1:1	ANGLES ±	
		DWN.	UNLESS OTHERWISE SPECIFIED	
		APPD.	DO NOT SCALE	
		JAK.	DRAWING	
ROSTRA TOOL COMPANY BRANFORD, CONNECTICUT 06405		PART NAME GM 12039500 CRIMP TOOL ASSEMBLY		

REV